

Protect and preserve

Double Containment Systems

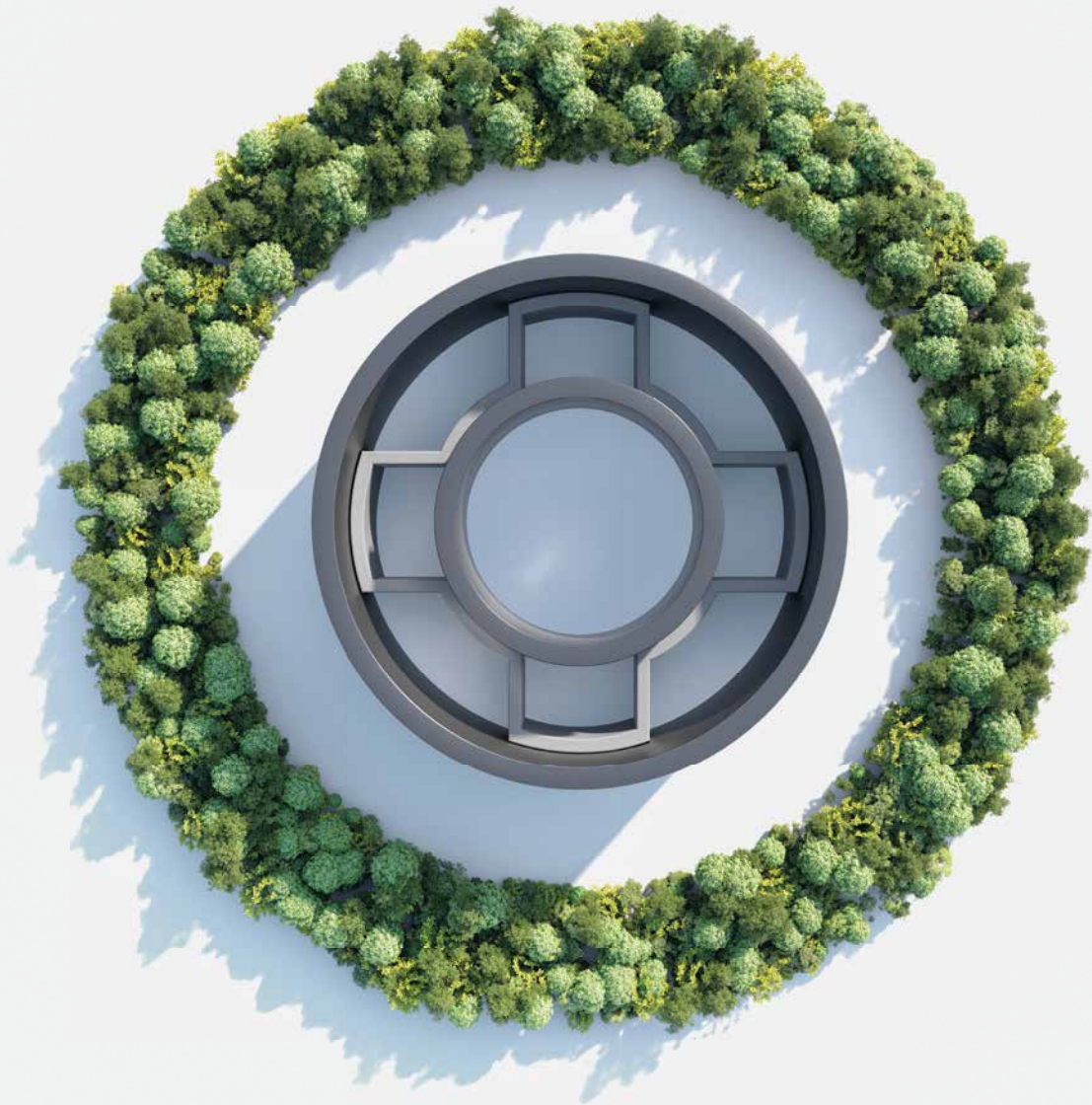

The pinnacle of protection

One solution, twice the protection

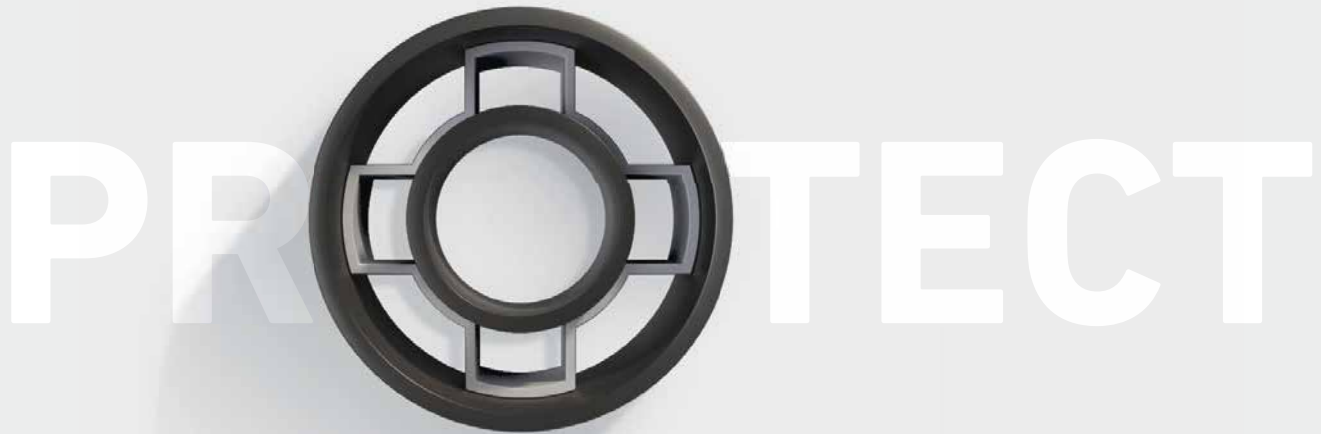

With more rigorously enforced legal restrictions for the safe transport of hazardous media, plant operators worldwide must fulfill environmental and employee protection standards. Not complying with legal regulations for the safe transport of hazardous media can result in millions of dollars of damages.

Handling hazardous media requires actions in the plant design to protect our environment, employees' health and safety, and consistent end-product quality. Due to environmental pollution and heavy accidents, organizations must ensure that their activities do not cause harm to anyone.

However, the use of critical media also poses a costly risk internally, especially for production-relevant equipment such as machines and plant components. In addition to hazardous chemicals, other media that appear harmless at first glance, such as water, can also pose a risk to the end-product safety or the IT-Infrastructure for plant operators.

Verification of the legal regulations and conducting of internal risk assessments are already of great importance in the planning phase to consider countermeasures.

GF Piping Systems' market-leading double containment portfolio is your solution to prevent costly environmental pollution, reduce employee accidents, and ensure higher end-product quality and plant availability.

Thanks to the double containment systems design, unexpected leakages of the medium carrying inner pipe are no longer a risk for plant operators. In case of a leakage, media remains in-between the inner and the containment pipe to ensure that escaping media cannot harm anyone. Various leak detection solutions enable operators to observe the monitoring room and contribute to fast leak detection.

With over 30 years of experience with double containment systems, GF Piping Systems is your reliable partner.



Complete piping system integrity

Projects across many industrial applications with diverse operation conditions require consistent solutions from planning to maintenance.

GF as a single source supplier contains it all. Our passion is to support our customers with a comprehensive solution based on a wide standard product portfolio with advanced competencies such as engineering services, tailor-made solutions, training, and planning relevant data like product-specific CAD libraries.



Total water flow preservation

Unexpected and creeping leaks in single industrial wastewater and chemical distribution lines have a massive impact on our global water reserves. Therefore, local regulations and measurements like double containment systems are defined to ensure our waters' safe condition.



Absolute peace of mind

Especially for the transport of corrosive liquids, hazardous media, and gases, material experts' involvement is important to ensure a long system lifetime.

GF specialists offer individual support and advice in selecting the right material and calculates the static evidence for your specific application. Thanks to the fully plastic double containment design, GF offers a corrosion-free and longer-lasting solution than metal alternatives.

Compliance with national and supranational regulations

GF Piping Systems' double containment system provide a sustained high level of product quality and outstanding performance in all applications. The clearly defined development and manufacturing processes of our worldwide specified systems are carried out based on all relevant standards and specifications.

Environmental protection is becoming increasingly important for governments and companies worldwide to ensure good water conditions and sustainable business success. Countries worldwide have defined laws and directives to protect and preserve our water quality, like the Water Framework Directive (2000/60/EC) in the EU and the 40 CFR 280 Requirements in the USA.

All Member States must incorporate these directives into national law and define concrete measures. Nations such as Germany (WHG §62, AwSV §17), the Netherlands (NRB, BRL-K903/08, PGS-31) and the USA (40 CFR 280) have defined double containment systems as a standard for the safe transport of hazardous media.

Employee protection

Double containment systems are a significant contribution to reduce personal accidents to zero. In the European Union, for example, plant operators are obliged to improve and ensure workers' safety at work without being subordinated to purely economic considerations (Directive 89/391/EEC).

Environmental protection

Double Containment systems are prescribed by national law and seen as well-established systems for the safe transport of hazardous media for outdoor and indoor, and especially for underground lines.

Operator consequences

Noncompliance with national and supranational regulations or negligent behavior with handling hazardous media is punishable by heavy fines for owners and managers and can lead to severe business damages for companies.





Peace of mind for all industries

Chemical Process Industry and Wastewater Treatment

Various hazardous media are required for manufacturing in many processes and transported via pressurized distribution and unpressurized wastewater piping systems next to your production facilities, employees, and environment.

Food and Beverage Industry

Cleaning in place (CIP) processes require highly concentrated cleaning solutions. Cleaning solutions are transported from storage tanks into dilution skids within the production area. Thanks to double containment systems, the end-product is not affected if media leaks from the inner pipe.

Data Centers

Active cooling is a major challenge for data center operators, especially to ensure the best availability and reliability. Double containment systems enable the safe transport of cooling media within the IT infrastructure efficiently and sustainably without any risk.

Affected market segments

Double containment systems are essential for all market segments where unexpected leakages can lead to damages to the environment, health, safety and quality.

Maintaining reputation

Double containment systems help to avoid accidents with hazardous media and thus resulting long-lasting image loss. GF Piping Systems provides a sustainable solution with double containment systems at a fraction of the potential business losses and clean-up costs.

The flexible solution for the safe transport of hazardous media

CONTAIN-IT Plus is the ideal solution for the safe transport of hazardous media. It combines the chemical resistance of dedicated inner pipe materials with a containment pipe's additional safety.

GF Piping Systems is your reliable partner from planning to maintenance. CONTAIN-IT Plus is as diverse as its customer - digital libraries, material experts, technical documentations, standard and advanced engineering services, and a broad standard portfolio with all relevant tools ensure the right fit for all individual projects.

The systems include many features that yield benefits for the plant owner, planner, and installer.

Advantages of plastic solution

- Corrosion-free
- UV- and weather-resistant
- Good chemical resistance
- Smooth internal surface
- Low weight and easy handling

Material – Chemical resistance

Our specialists offer individual support and advice in selecting the right material for your specific application conditions.

Know-How – Technical documentation

Our extensive know-how is fully documented in detail in our technical manuals, planning fundamentals and application guides.



Applications

The extremely flexible system offers a wide range of applications, including for the chemical process industry, micro-electronics, water and waste water treatment, mining or data centers.

Static Evidence & Stress Calculation

The free of charge standard service based on the questionnaire for static evidence & stress calculation provides further information about the feasibility and fix point forces.

Static Evidence for networks

Based on your preliminary drawings, GF Piping Systems calculates the static evidence of your piping network and proposes improvements. Every calculated evidence is verifiable by 3rd parties (such as PE, TUV and others).

Type	Details
Material	<p>Containment pipe: PE100 & PVC-U (transparent)</p> <p>Inner pipe: PVC-U, PVC-C, PE, PP, PVDF, ECTFE, PFA</p>
Pressure rating	<p>Containment piping system: PE100: PN10/PN16 PVC-U transparent: PN1 Valves: PN6</p> <p>Inner piping system: Varies according to dimension and material</p>
Operational temperature	-50 °C to +140 °C (depending on inner pipe)
Joining technology	<p>Containment pipe connection: Electrofusion (PE), EPDM- Coupler (PVC-U)</p> <p>Inner pipe connection: Cementing, Socket fusion, Butt Fusion, IR Fusion</p>

Designed for the highest demands

CONTAIN-IT Plus piping system offers the right fit and quality for all industrial applications and projects worldwide. The variety of pipes, fittings, valves, and jointing technologies are as diverse as our customers and their individual challenges.

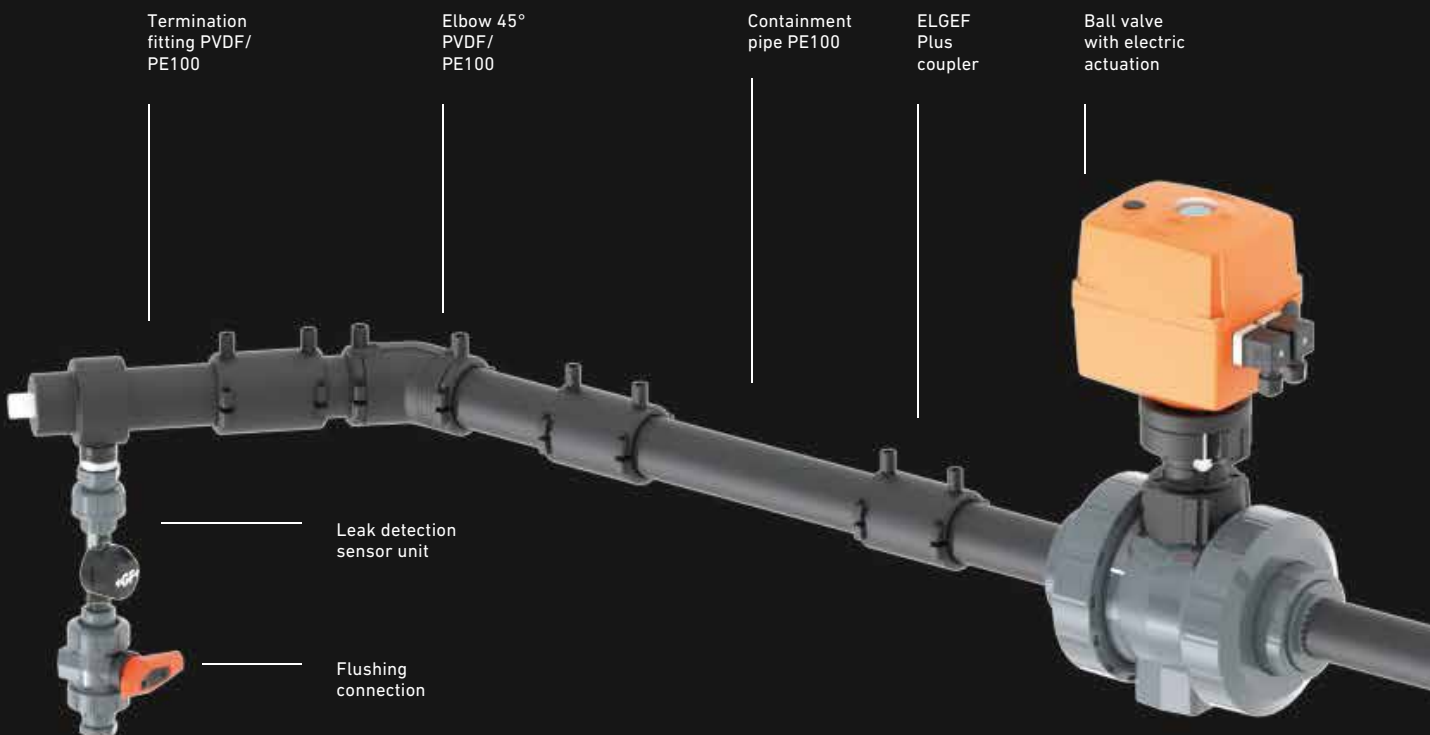

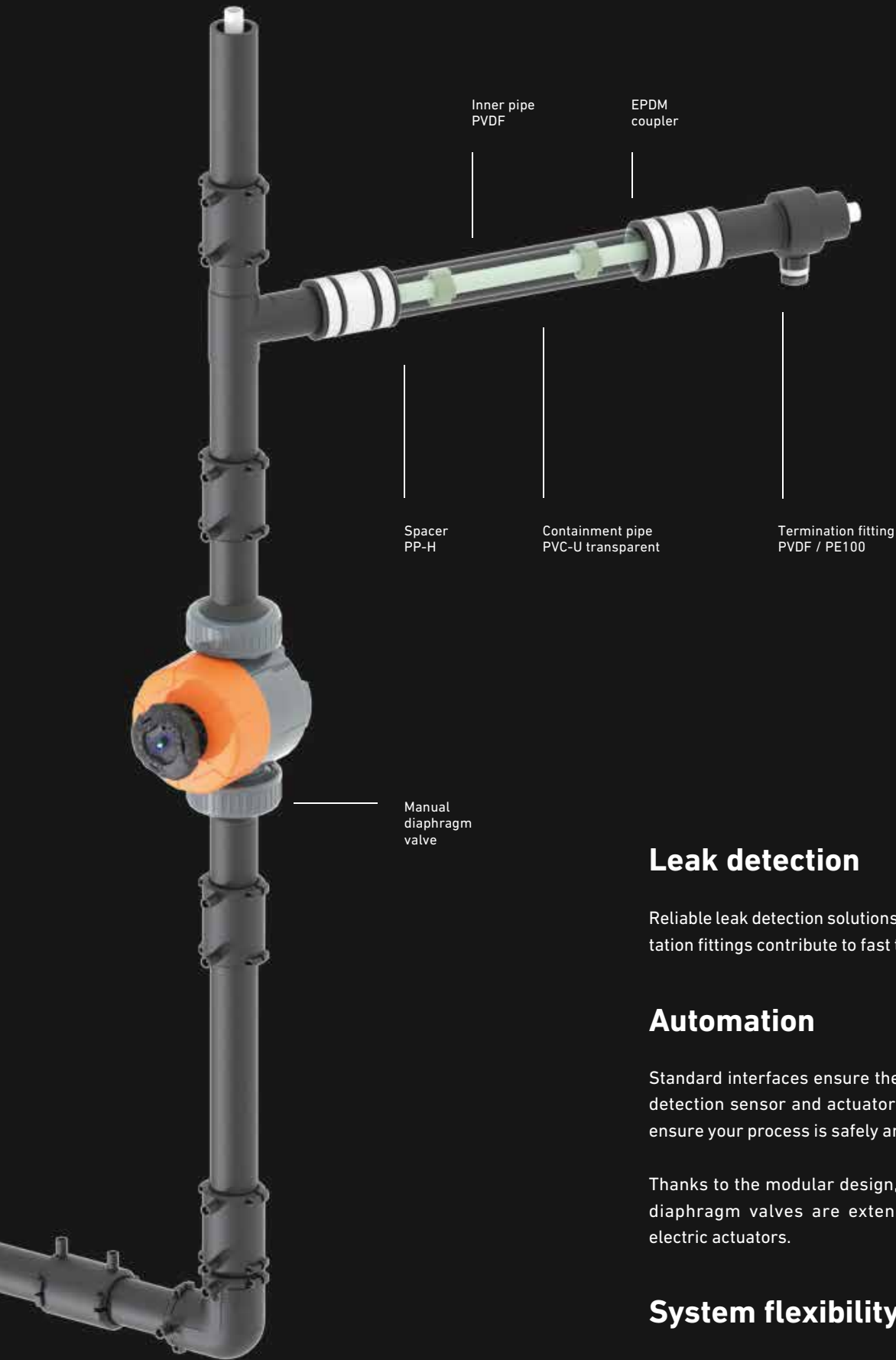

Leak detection

Reliable leak detection solutions in combination with segmentation fittings contribute to fast troubleshooting.

Automation

Standard interfaces ensure the easy integration of the leak detection sensor and actuators into all control systems to ensure your process is safely and efficiently operated.

Thanks to the modular design, the pressure-tight ball and diaphragm valves are extendable with pneumatic and electric actuators.

System flexibility

The worldwide presence of GF Piping Systems' customizing team ensures the system is tailored to your needs. Standardized processes guarantee the highest level of quality.

Safe and fast installation

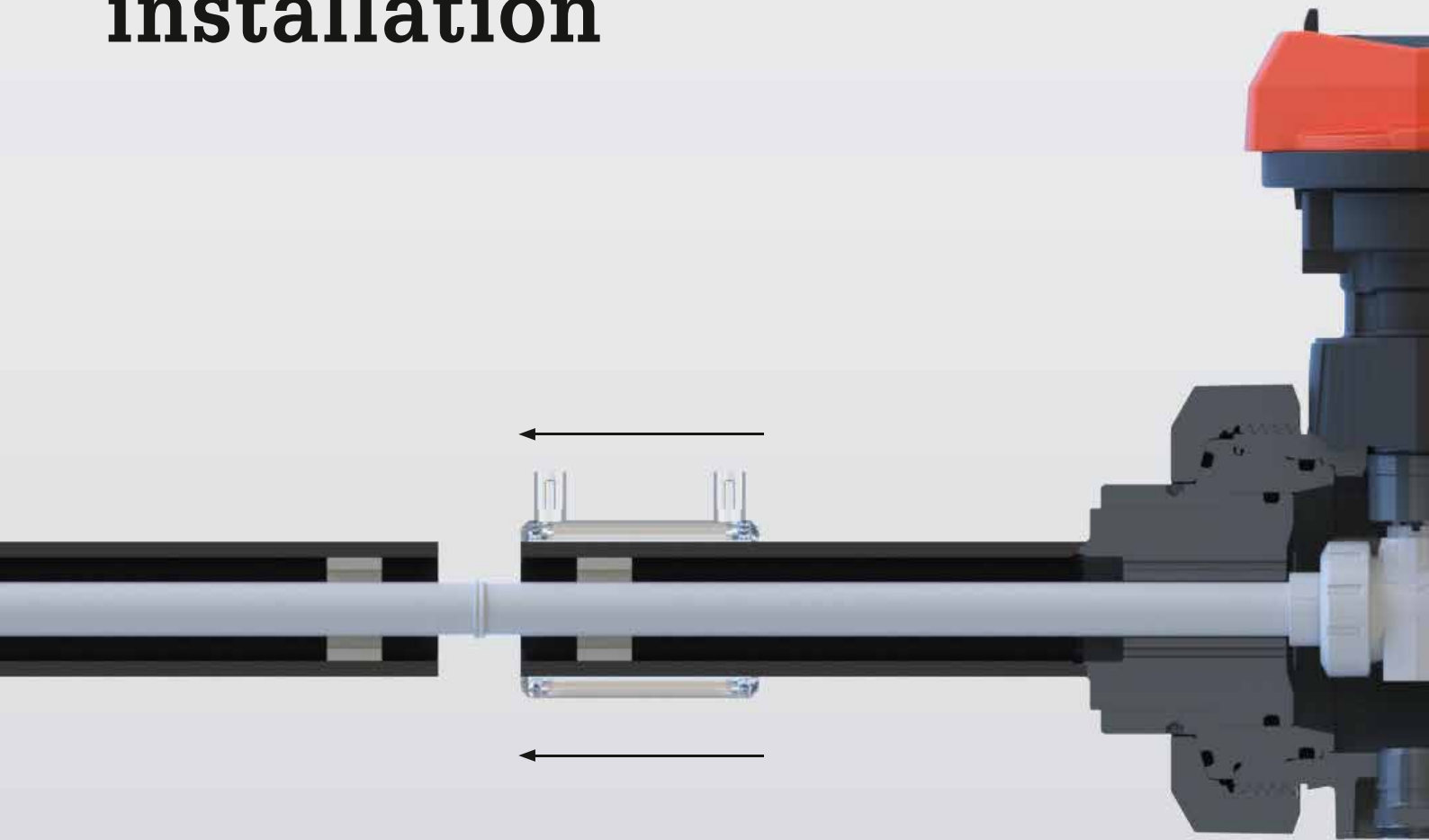

Safe jointing technology

CONTAIN-IT Plus is based on the principle of the so-called initial jointing of the inner pipe. With this technology, the inner and containment pipes can be installed separately. This permits laying a double containment pipeline analogous to a single pipeline. The DVS guidelines (German Welding Society), which stipulate visual inspection of each joint, are strictly observed.



Making "last joint" easy

The so-called "last joint," which occurs with every change of direction in other systems and usually has to be done blind, does not exist with this method. After joining the inner pipe, there is a 30 mm gap between the ends of the containment pipe. This gap serves to test the inner pipe according to DVS guidelines.

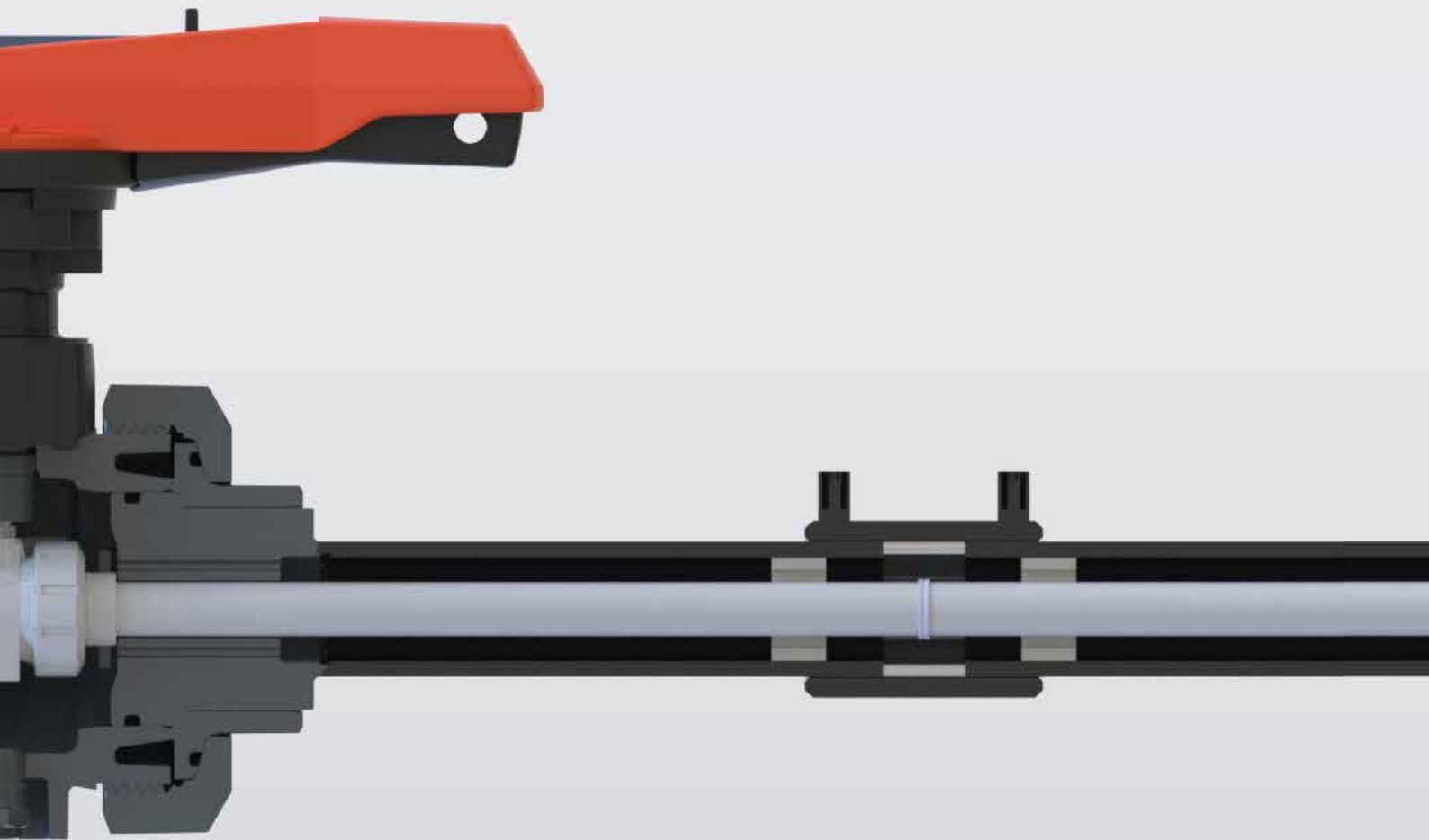

Proven installation quality

After the pressure test is successfully completed for the inner pipe, this gap will be closed with a snap ring. Finally, an ELGEF Plus coupler or an EPDM coupler is placed over the snap ring, and the pipe ends, and then fused or screwed down.



Global Training opportunities

Project specific trainings provide the opportunity to gain confidence in working with GF Piping Systems tools and systems. The trainings are available globally and are carried out by local teams of experts.

The easy and reliable solution for retrofit and new installations

The Contain-It™ secondary containment piping system comprises lightweight and clear PVC split pipes and fittings that are easy to fit over primary piping systems. When combined with GF's variety of primary piping systems, the Contain-It™ system is suitable for virtually any piping application, from pressure process lines to drainage waste systems.

With the pipe split along its length, the Contain-It™ piping system can be installed over virtually any carrier system. The carrier system can be tested without interference from the containment piping. Any leaks found during testing are easily repaired. A leak detection cable can be installed as the split components are assembled, eliminating the need for time-consuming cable pulling or the inclusion of lines to pull the cable through. Containment piping can be retrofitted over plastic and metal systems above and below ground, protecting employees, equipment, and the environment.

Applications

Contain-It™'s retrofit capability and chemical resistance make this an ideal choice for containment piping of chemical process lines.

Solid Pipe

Solid pipe may be combined with split fittings in installations that do not require retrofit capability or where it is preferred to pull a leak detection cable. Solid pipe is available in 3" (90 mm), 4" (107 mm) and 6" (160 mm).

Flexible Terminations

Flexible adapters allow connection to metal or chemical resistant plastic carrier systems other than PVC.

Centralizer

Centralizers center and support the carrier pipe. They are available for IPS, metric, and CTS carrier pipes.



Type	Details
Material	Clear Polyvinyl Chloride (PVC)
Pressure rating	Containment piping system: 32 PSI for PVC bonded termination 5 PSI for flexible terminations
Operational temperature	Containment pipe: 32°F –140°F (0°C – 60°C)
Joining technology	Adhesive joint

Double-See®



Double-See® is fast and easy to install and is available with a complete selection of pipe, fittings, leak detection, and access tees, closure couplings, and termination fittings. Additionally, an innovative “valve-in-valve” design allows for a full containment pressure rating.

Applications

The versatility of Double-See® makes it an ideal containment system for water and wastewater treatment, chemical processing, delivery and dosing, microelectronics, metal plating, and surface finishing, and life sciences applications.

Type	Details
Material	<p>Polyvinyl Chloride (PVC) Grey</p> <p>Chlorinated Polyvinyl Chloride (CPVC)</p>
Pressure rating	<p>Containment piping system: 50 PSI 5 PSI for closure coupling applications</p> <p>Inner piping system: Varies according to dimension and material</p>
Operational temperature	<p>PVC Schedule 80 and 40: 32°F–140°F (0°C–60°C)</p> <p>CPVC Schedule 80: 32°F–200°F (0°C–93°C)</p>
Joining technology	Solvent (Cement) Weld

FUSEAL Squared®



FUSEAL Squared® double containment piping is ideal for corrosive waste conveyance systems where secondary containment is required or desired. It offers the same performance and reliability our customers have come to expect from the FUSEAL drainage system.

Applications

FUSEAL Squared has chemical and physical properties that make it an ideal and complete solution for handling corrosive, chemical waste in buried laboratory and industrial DWV applications. FUSEAL Squared® is suitable for use in virtually every application where acids, bases, and solvents are drained and where environmental protection is key.

Type	Details
Material	Polypropylene Flame Retardant (PPFR)
	Polypropylene Non-Flame Retardant (PPNFR)
Pressure rating	Inner pipe: Polyvinylidene Fluoride (PVDF) Primary only
	30 foot (15 PSI) maximum head pressure test for DWV applications
Operational temperature	Up to 50 PSI for pressure waste applications (subject to manufactures review of design)
	PP: 32°F – 212°F (0°C – 100°C)
Joining technology	PVDF: 32°F – 280°F (0°C – 138°C)
	Electrofusion

One partner from planning to commissioning

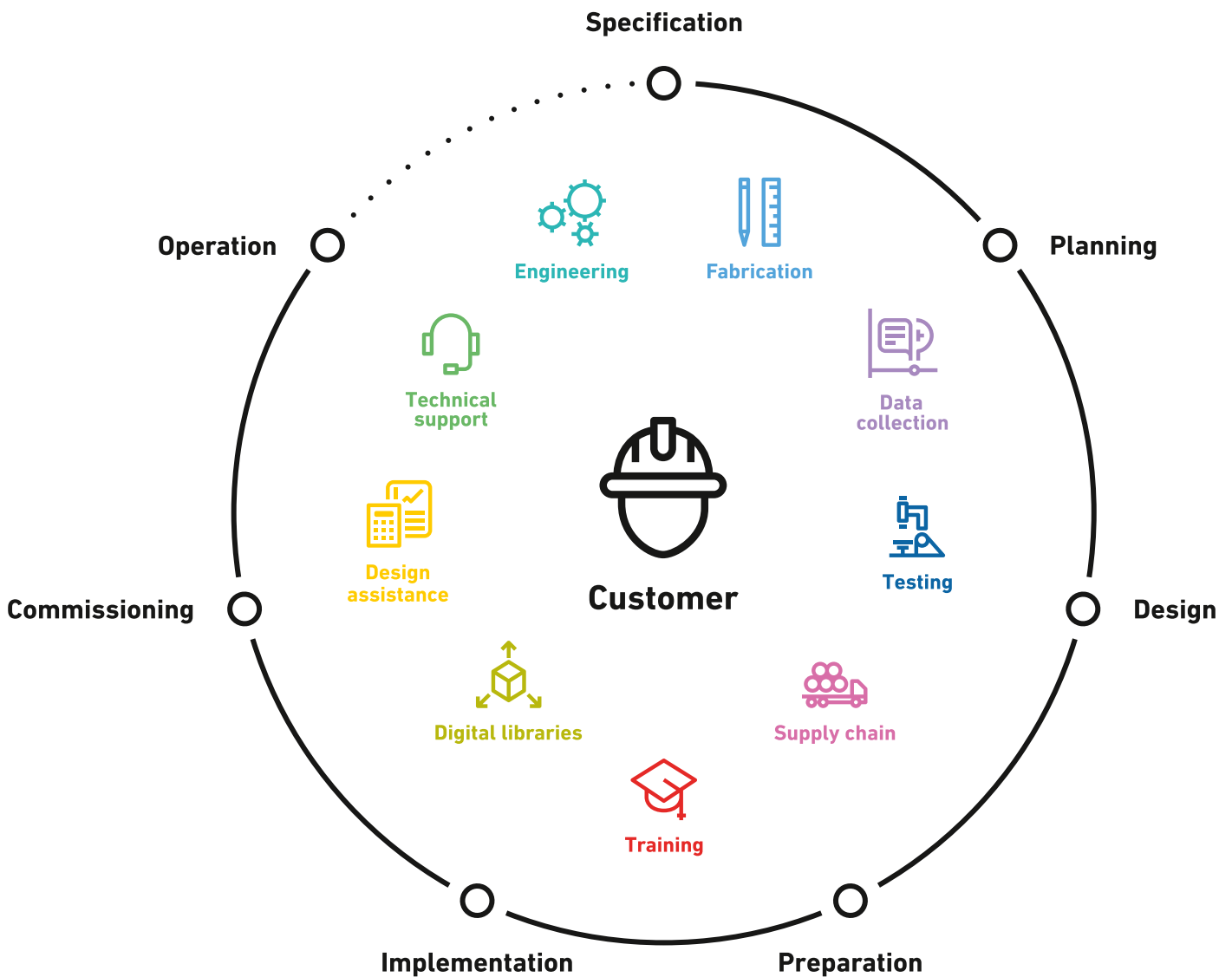



Ready when you are

With Specialized Solutions, the global leader GF Piping Systems provides project support every step of the way to achieve construction excellence. Allowing owners and planners to concentrate on their daily business without interruption.

Engineering

Increase the efficiency of your project with tailor-made analysis packages from GF Piping Systems. Minimize project risks by diminishing incorrect calculations or wrong material selection. Rely on GF's experience in fast project implementation and choose our durable, safe, and reliable piping systems delivery. Established knowledge, guiding you through.

Digital Libraries

The libraries cover three key areas for designing, creating, and maintaining a project: Building Information Modeling, the Plant Design Software, and the CAD Library helping you reduce costs and construction times while ensuring design accuracy and integrity. Reduce time and effort while ensuring design accuracy and integrity.

Custom Product Design and Prefabrication

Focusing on your individual needs and application, GF's customizing teams forge tailored solutions, developing custom-made parts to complete systems or special solutions produced in small series, individual consulting, and off-site prefabrication. Through our global network, we offer a wide range of comprehensive solutions. Tailored innovation, inspired by you.

More information at

gfps.com/specialized-solutions

Next steps

In this brochure, you have received the most important information and technical details. But nothing replaces a personal conversation with an expert from GF Piping Systems. It is all about your needs and how we can support you in your daily business challenges. If you have not already done so, make an appointment today.

Find your local contact on the back cover of this brochure or visit our GF Piping Systems website, where you will find specialized contact persons in your area. You will also find additional information on our products, including technical datasheets, operating instructions, and relevant certificates and approvals.

More information at

gfps.com/doublecontainment

